

12.3.1 Masonry Compressive Strength

An engineer bases the design of masonry structural systems on a certain “specified compressive strength of masonry” (f'_m), on which the allowable axial, flexural, compressive, shear, and bearing stresses are based. Under IBC and MSJC Code requirements, the contractor must verify to the engineer by one of two methods that the proposed materials and construction will meet or exceed this strength. The contractor may elect to use the *unit strength method* based on the combined strength of the masonry units and mortar as determined by tables in the code, or the *prism test method*.

Projects that are not large enough to justify the cost of prism testing generally use the unit strength method. Through submittals, the contractor certifies that the proprietary masonry units specified in the contract documents or the generic masonry units selected to comply with specified ASTM standards are of sufficient strength to produce the “specified compressive strength” when combined with ASTM C476 grout and either the specified ASTM C270 mortar type (M, S, or N) or the ASTM C270 mortar type (M, S, or N) selected to produce the “specified compressive strength” (see Fig. 12-32). The proportion specification of ASTM C270 (the default) governs, as well as the proportion specification of ASTM C476. Both the proportion specifications of ASTM C270 and C476 and the unit strength method of determining “specified compressive strength” are very conservative and usually produce mortar and masonry of greater strength than the minimum required by the

The *unit strength method* of verifying specified compressive strength uses the tables below to show the net area compressive strength produced by combining units of a specific strength with Type M, S, or N mortar. The unit strength method of verifying f'_m may be used instead of laboratory prism testing when:

- units conform to ASTM requirements
- bed joint thickness does not exceed 5/8 in., and
- grout meets ASTM C476 requirements, or grout compressive strength is equal to f'_m but not less than 2000 psi

Required Net Area Compressive Strength of Clay Masonry Units (psi)		For Net Area Compressive Strength of Masonry (psi)	Required Net Area Compressive Strength of Concrete Masonry Units (psi)		For Net Area Compressive Strength of Masonry (psi)
When Used With Type M or S Mortar	When Used With Type N Mortar		When Used With Type M or S Mortar	When Used With Type N Mortar	
1,700	2,100	1,000	1,250	1,300	1,000
3,350	4,150	1,500	1,900	2,150	1,500
4,950	6,200	2,000	2,800	3,050	2,000
6,600	8,250	2,500	3,750	4,050	2,500
8,250	10,300	3,000	4,800	5,250	3,000
9,900	--	3,500			
13,200	--	4,000			

Figure 12-32 MSJC and International Building Code tables for unit strength method of verifying masonry compressive strength (f'_m). (From International Building Code 2003; and *Masonry Standards Joint Committee, Specifications for Masonry Structures, ACI 530.1/ASCE 6/TMS 602-02*)

design. This is a built-in high safety factor, but it does not produce the most cost-efficient design.

For large projects where efficiency in design can produce a cost savings by optimizing the use of materials in mortar and grout designs, the contractor may elect to use the prism test method to verify “specified compressive strength” (see Fig. 12-33). Using this method, the contractor hires a testing laboratory to produce mortar and grout mix designs in accordance with the minimum property specification of ASTM C476 and ASTM C270, respectively, which, when combined with the specified or selected masonry units, will produce the “specified compressive strength” when prisms are laboratory tested in accordance with ASTM C1314.

The process of verifying the compressive strength of masonry is similar to specifying concrete for small projects by stipulating a certain number of sacks of cement per cubic yard and a certain water-cement ratio (comparable to the unit strength method), and to specifying concrete for large projects by requiring a minimum compressive strength for which the contractor proposes a laboratory mix design (comparable to preconstruction prism testing) that is verified by cylinder tests of field-sampled concrete (comparable to field-constructed prism testing).

If the prism test method is used, ASTM C780 is used for preconstruction and construction evaluation of mortar mixes, ASTM C1019 is used for preconstruction and construction evaluation of grout mixes, and ASTM C1314 is used for prism tests (see Fig. 12-33). If the unit strength method is used, no testing is required.

12.3.2 Differential Movement

Buildings are dynamic structures whose successful performance depends on allowing the differential movement of adjoining or connecting elements to occur without excessive stress or its resulting damage. All building materials experience volumetric changes from temperature fluctuations, and some experience moisture-related movements as well. Structural movements include column shortening, elastic deformation, creep, and wind sway. The differential rates and directions of movements must be accommodated by flexible connections and movement joints (refer to Chapter 9).

Structural connections may be required to permit movement in some directions and transfer applied loads in others. For example, at the joint

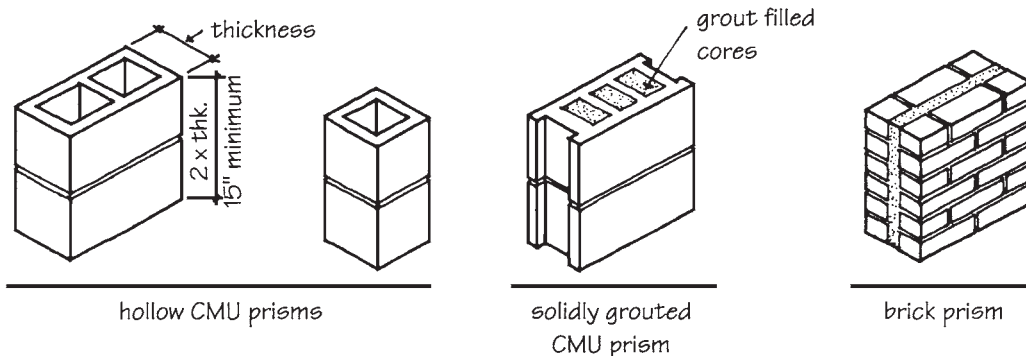

Figure 12-33 ASTM C1314 test prisms for masonry assemblages of units, mortar, and grout.